

Ultimate Electrostatics Assignment

Key Formulae:

$$F = k \frac{Q_1 Q_2}{r^2}$$

$$E = \frac{F}{Q}$$

$$E = \frac{kQ}{r^2}$$

$$\Delta V = \frac{\Delta E_p}{Q}$$

$$E = \frac{\Delta V}{d}$$

$$E_p = k \frac{Q_1 Q_2}{r}$$

$$V = \frac{kQ}{r}$$

0108

1.

Which of the following best illustrates the electric field between parallel plates with opposite electric charges?

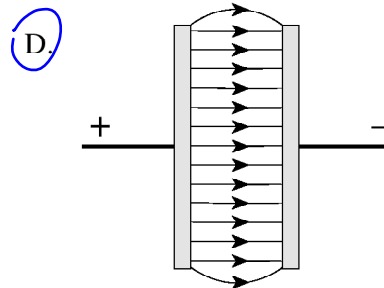
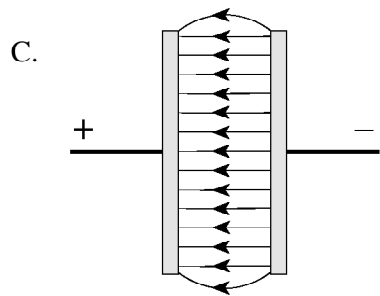
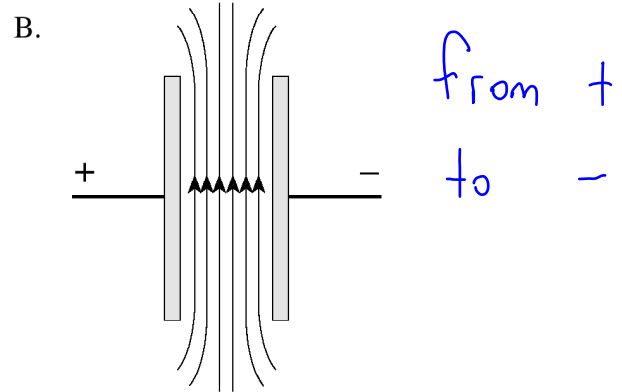
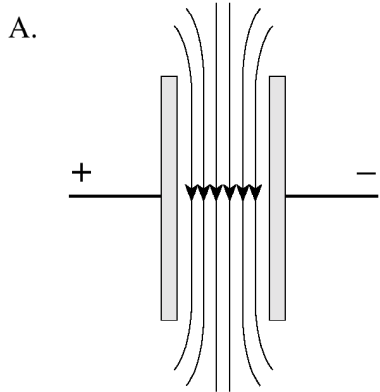

$$\vec{E} = \frac{kq}{r^2} = \frac{(9 \times 10^9)(92 \times 1.6 \times 10^{-19})}{(2.5 \times 10^{-10})^2} = 2.1 \times 10^{12}$$

2.

The atomic nucleus of uranium contains 92 protons. What is the direction and magnitude of the electric field 2.5×10^{-10} m from this nucleus?

	DIRECTION OF ELECTRIC FIELD	MAGNITUDE OF ELECTRIC FIELD
A.	towards nucleus ✗	5.3×10^2 N/C ✗
B.	away from nucleus ✓	5.3×10^2 N/C ✗
C.	towards nucleus ✗	2.1×10^{12} N/C ✓
<u>D.</u>	away from nucleus ✓	2.1×10^{12} N/C ✓

from +
to -

3.

A 0.16 C charge is moved in an electric field from a point with a potential of 25 V to another point with a potential of 95 V. How much work was done to move this charge?

- A. 4.0 J
- B. 11 J
- C. 15 J
- D. 19 J

$$W = \Delta PE \quad \text{and} \quad \Delta V = \frac{\Delta PE}{q}$$

$$W = \Delta V q$$

$$W = (95 - 25)(.16) = 11.2 \text{ J}$$

4.

A beam of electrons is directed to a region between oppositely charged parallel plates as shown in the diagram below.

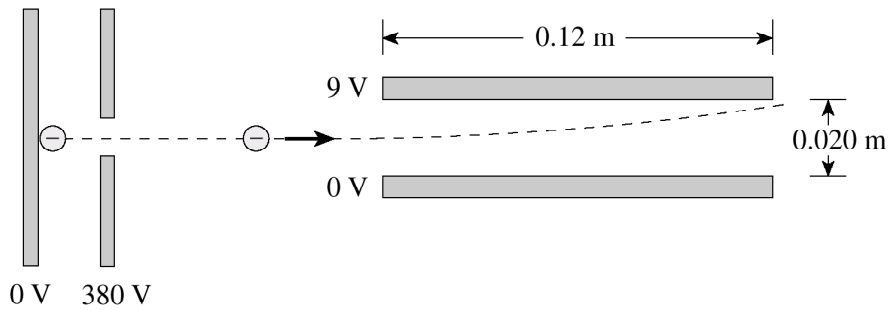

- a) The electron beam is produced by accelerating electrons through an electric potential difference of 380 V. What is the speed of the electrons as they leave the 380 V plate?

(3 marks)

$$KE_i + PE_i = KE_f + PE_f$$

$$PE_i = \frac{1}{2} m v_f^2$$

$$qV = \frac{1}{2} m v_f^2$$

$$v_f = \sqrt{\frac{2qV}{m}} = \sqrt{\frac{2(1.6 \times 10^{-19})(380)}{9.11 \times 10^{-31}}}$$

$$v_f = 1.15 \times 10^7 \text{ m/s}$$

- b) What is the electrostatic force on electrons in the region between the horizontal plates when they are connected to a 9.0 V potential difference? **(4 marks)**

$$\vec{F} = \vec{E} q, \text{ where } \vec{E} = \frac{\Delta V}{d}$$

$$\vec{F} = \frac{\Delta V q}{d} = \frac{9(1.6 \times 10^{-19})}{.02}$$

$$\vec{F} = 7.2 \times 10^{-17} \text{ N}$$

0106

5.

A positively charged oil droplet is in a vertical electric field.

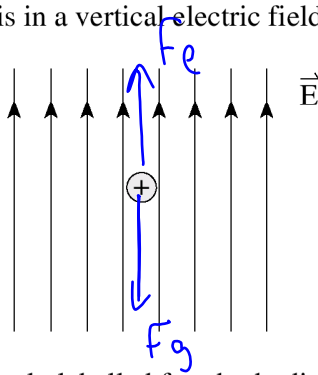

Which of the following is a correctly labelled free-body diagram showing the forces acting on the oil droplet?

A.

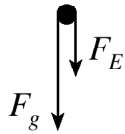

B.

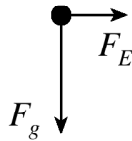

C.

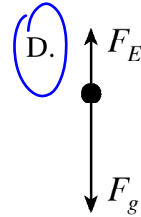
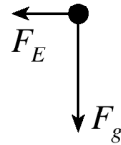

6.

What are the magnitude and direction of the electric field between the plates in the situation shown below?

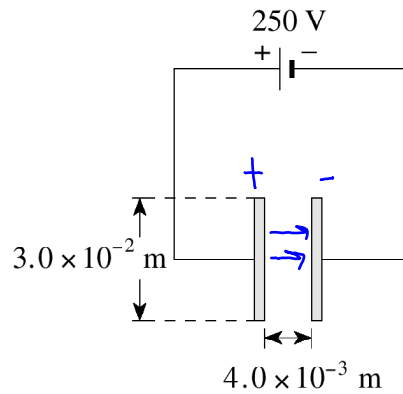

$$\vec{E} = \frac{V}{d} = \frac{250}{4 \times 10^{-3}} = 62500 \text{ V/m}$$

	DIRECTION OF FIELD	MAGNITUDE OF FIELD (V/m)
A.	left <input checked="" type="checkbox"/>	8.3×10^3 <input checked="" type="checkbox"/>
B.	right <input checked="" type="checkbox"/>	8.3×10^3 <input checked="" type="checkbox"/>
C.	left <input checked="" type="checkbox"/>	6.3×10^4 <input checked="" type="checkbox"/>
(D.)	right <input checked="" type="checkbox"/>	6.3×10^4 <input checked="" type="checkbox"/>

7.

Electric charges Q_1 and Q_2 are arranged as shown in the diagram below.

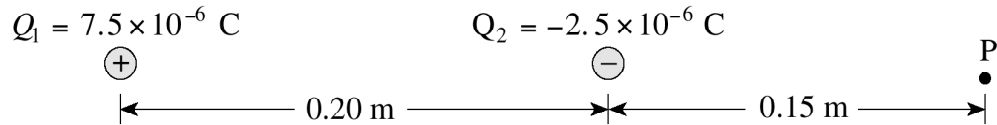

What is the electric potential at point P? *not energy! Voltage!* (7 marks)

$$\begin{aligned}\sum V &= V_1 + V_2 \\ &= \frac{kq_1}{r_1} + \frac{kq_2}{r_2} \\ &= \frac{(9 \times 10^9)(7.5 \times 10^{-6})}{.35} + \frac{(9 \times 10^9)(-2.5 \times 10^{-6})}{.15} \\ &= 193000 + -150,000 \\ &= 4.3 \times 10^4 \text{ V}\end{aligned}$$

8.

A student decides to investigate how electric field varies along the line connecting two positive point charges. Charge Q_2 is greater than charge Q_1 .



Using principles of physics, describe the electric field along the line from Q_1 to Q_2 . (4 marks)

Initially, the electric field points to the right, and it decreases as we move right. At some point closer to Q_1 , the electric field will be zero. It will then begin to increase, but point to the left.

0101

9.

Which of the following best describes how electric potential varies with distance in the region around a point charge?

- A. $V \propto r$
- B. $V \propto \frac{1}{r}$
- C. $V \propto r^2$
- D. $V \propto \frac{1}{r^2}$

voltage, not energy!

$$V = kq \frac{1}{r}$$

10.

Three **identical** positive electric charges are fixed as shown in the diagram below.

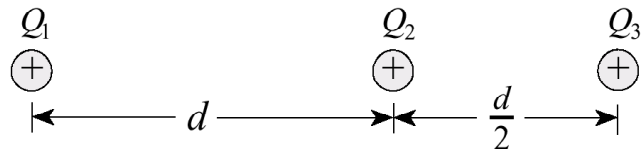

What is the direction of the net electric force on Q_2 due to Q_1 and Q_3 ?

- A. to the left
- B. to the right
- C. the net force is zero
- D. cannot be determined



11.

In an experiment, a positively charged oil droplet weighing 6.5×10^{-15} N is held stationary by a vertical electric field as shown in the diagram.

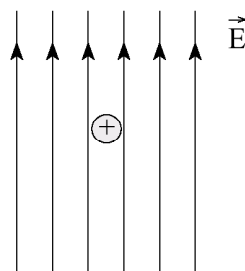

$$F_g = F_e$$
$$mg = \vec{E} q$$

If the electric field strength is 5.3×10^3 N/C, what is the charge on the oil droplet?

- A. 1.2×10^{-18} C
- B. 3.4×10^{-11} C
- C. 4.1×10^4 C
- D. 8.2×10^{17} C

$$q = \frac{mg}{\vec{E}} = \frac{6.5 \times 10^{-15}}{5.3 \times 10^3} = 1.22 \times 10^{-18} \text{ C}$$

12.

Electric charges are arranged as shown in the diagram below.

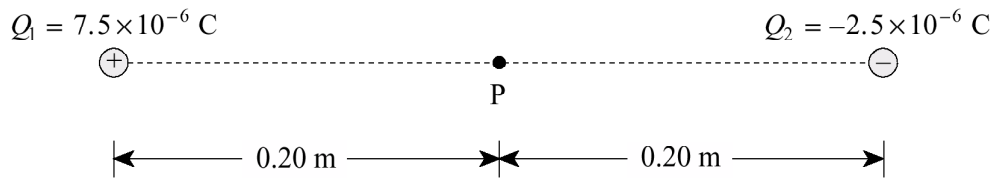

What is the electric field (magnitude and direction) at point P midway between the charges?

(7 marks)

$$E_1 = \frac{kq_1}{r_1^2} = \frac{(9 \times 10^9)(7.5 \times 10^{-6})}{.2^2} = 1687500 \text{ N/C right}$$

$$E_2 = \frac{kq_2}{r_2^2} = \frac{(9 \times 10^9)(2.5 \times 10^{-6})}{.2^2} = 562,500 \text{ N/C right}$$

$$\Sigma \vec{E}_{\text{total}} = 2.25 \times 10^6 \text{ N/C right}$$

0008

13.

The electric field is uniform between

- A. two positive point charges.
- B. two negative point charges.
- C. two opposite point charges.
- D.** two oppositely charged parallel plates.

14.

What is the magnitude and direction of the electric field at point P due to the two fixed charges?

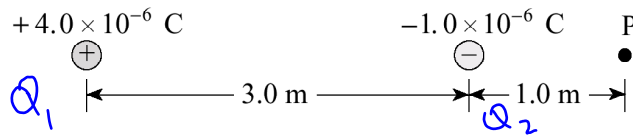

ELECTRIC FIELD AT POINT P		
	MAGNITUDE	DIRECTION
A.	6 800 N/C ✓	Right ✗
B.	6 800 N/C ✓	Left ✓
C.	11 000 N/C ✗	Right ✗
D.	11 000 N/C ✗	Left ✓

$$\begin{aligned}
 \vec{E}_1 &= \frac{kq_1}{r^2} \\
 &= \frac{(9 \times 10^9)(4 \times 10^{-6})}{4^2} \\
 &= 2250 \text{ N/C right} \\
 \vec{E}_2 &= \frac{(9 \times 10^9)(1 \times 10^{-6})}{1^2} \\
 &= 9000 \text{ N/C left}
 \end{aligned}$$

15.

A proton with kinetic energy of $2.1 \times 10^{-17} \text{ J}$ is moving into a region of charged parallel plates. The proton will be stopped momentarily in what region?

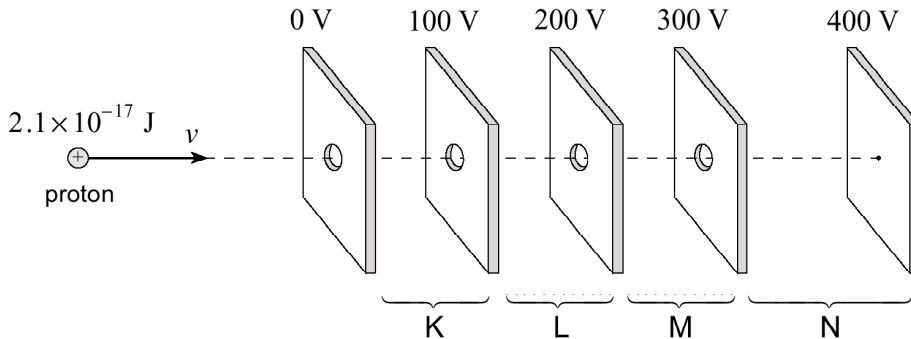

- A. Region K
- B.** Region L
- C. Region M
- D. Region N

$$\begin{aligned}
 \Delta PE &= \Delta KE \\
 q\Delta V &= 2.1 \times 10^{-17} \\
 \Delta V &= \frac{2.1 \times 10^{-17}}{1.6 \times 10^{-19}} = 131.25 \text{ V} \\
 &\text{Section L}
 \end{aligned}$$

16.

A proton, initially at rest at point X, will have what speed at point Y?

(7 marks)



$$PE_i + KE_i = PE_f + KE_f$$

$$\frac{kq_1q_2}{r_i} + 0 = \frac{kq_1q_2}{r_f} + \frac{1}{2}mv_f^2$$

$$\frac{(9 \times 10^9)(3.5 \times 10^{-6})(1.6 \times 10^{-19})}{1} - \frac{(9 \times 10^9)(3.5 \times 10^{-6})(1.6 \times 10^{-19})}{3} = \frac{1}{2}mv_f^2$$

$$5.04 \times 10^{-15} - 1.68 \times 10^{-15} = \frac{1}{2}mv_f^2$$

$$V_f = \sqrt{\frac{3.36 \times 10^{-15}}{(0.5)(1.67 \times 10^{-27})}} = 2.0 \times 10^6 \text{ m/s}$$

0006

17.

An electron in the electric field has an electric force acting on it in what direction?

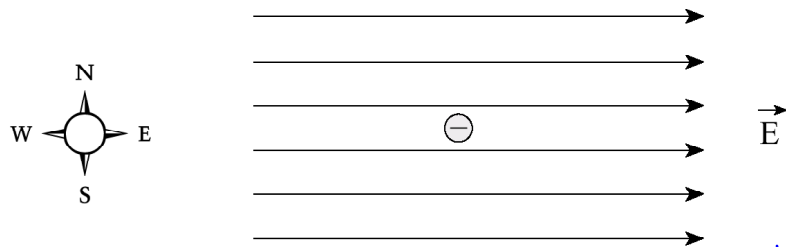

- A. North
- B. South
- C. East
- D. West

positive charge would move E

∴ negative will move W.

18.

What is the electric potential at point P due to the two fixed charges as shown?

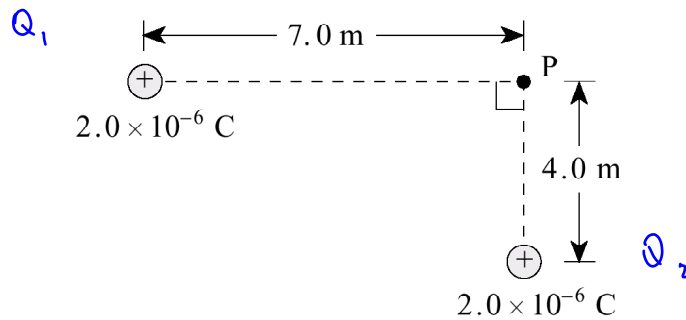

- A. 1 200 V
- B. 1 500 V
- C. 5 200 V
- D. 7 100 V

$$V_{\text{total}} = V_1 + V_2$$

$$= \frac{kq_1}{r_1} + \frac{kq_2}{r_2}$$

$$V = \frac{(9 \times 10^9)(2 \times 10^{-6})}{7} + \frac{(9 \times 10^9)(2 \times 10^{-6})}{4}$$

$$= 2571 + 4500 = 7.1 \times 10^3 \text{ V}$$

19.

A moving proton has 6.4×10^{-16} J of kinetic energy. The proton is accelerated by a potential difference of 5 000 V between parallel plates.

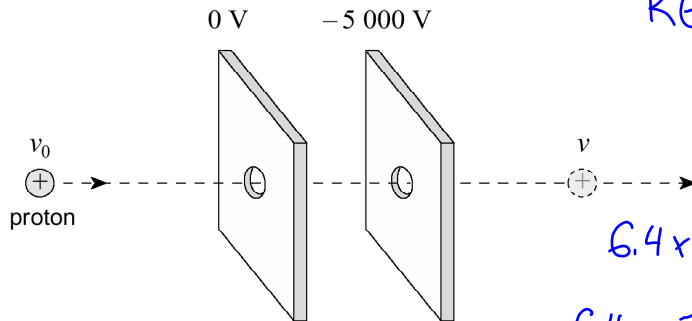

$$KE_i + PE_i = KE_f + PE_f$$

$$6.4 \times 10^{-16} + qV = \frac{1}{2} m v_f^2$$

$$\frac{6.4 \times 10^{-16} + (1.6 \times 10^{-19})(5000)}{\frac{1}{2} m} = v_f^2$$

The proton emerges from the parallel plates with what speed?

- A. 8.8×10^5 m/s
- B. 9.8×10^5 m/s
- C. 1.3×10^6 m/s**
- D. 1.8×10^6 m/s

$$\sqrt{\frac{6.4 \times 10^{-16} + (1.6 \times 10^{-19})(5000)}{(0.5)(1.67 \times 10^{-27})}} = v_f \quad v_f = 1.3 \times 10^6 \text{ m/s}$$

20.

a) How much work is done in moving an electron from point X to point Y?

(5 marks)

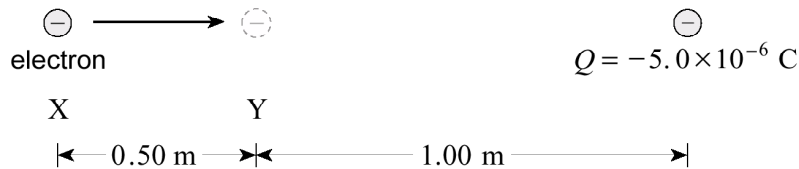

$$\begin{aligned}
 W &= \Delta PE = PE_f - PE_i = \frac{kq_1q_2}{r_f} - \frac{kq_1q_2}{r_i} \\
 &= \frac{(9 \times 10^9)(-1.6 \times 10^{-19})(-5 \times 10^{-6})}{1} - \frac{(9 \times 10^9)(-1.6 \times 10^{-19})(-5 \times 10^{-6})}{1.5} \\
 &= 7.2 \times 10^{-15} - 4.8 \times 10^{-15} \\
 &= 2.4 \times 10^{-15} \text{ J}
 \end{aligned}$$

b) What is the potential difference between point X and point Y?

(2 marks)

$$\Delta V$$

$$\Delta V = V_y - V_x = \frac{kq}{r_f} - \frac{kq}{r_i}$$

$$\Delta V = \frac{(9 \times 10^9)(5 \times 10^{-6})}{1} - \frac{(9 \times 10^9)(-5 \times 10^{-6})}{1.5}$$

$$\Delta V = -45000 - -30000$$

$$\Delta V = -15000 \text{ V} = \pm 1.5 \times 10^4 \text{ V}$$

0001

21.

Which of the following diagrams shows the electric field between two equal but opposite charges?

A.

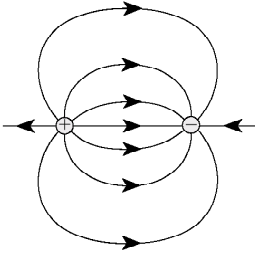

B.

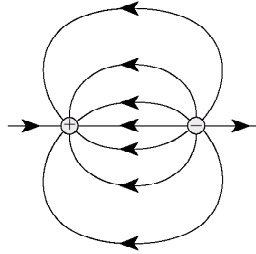

~~C.~~

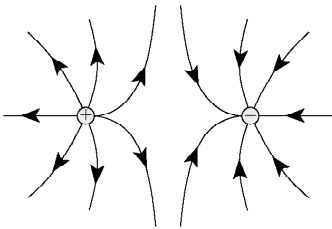

~~D.~~

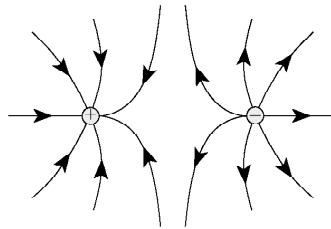

22.

A proton initially at rest is accelerated between parallel plates through a potential difference of 700 V.

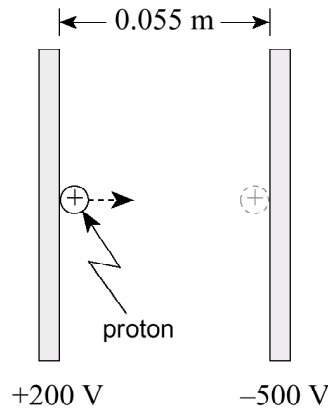

$$K\cancel{E}_i + P\cancel{E}_i = K\cancel{E}_f + P\cancel{E}_f$$

$$0 = 0$$

$$qV = \frac{1}{2}mv_f^2$$

$$v_f = \sqrt{\frac{2qV}{m}}$$

What is the maximum speed reached by the proton?

A. 8.6×10^4 m/s

B. 3.1×10^5 m/s

C. 3.7×10^5 m/s

D. 1.6×10^6 m/s

$$v_f = \sqrt{\frac{2(1.6 \times 10^{-19})(700)}{1.67 \times 10^{-27}}} = 3.66 \times 10^5 \text{ m/s}$$

23.

What are the magnitudes of the electric field and the electric potential at point P midway between the two fixed charges?

\vec{E} can't be zero, since both E fields are to the right

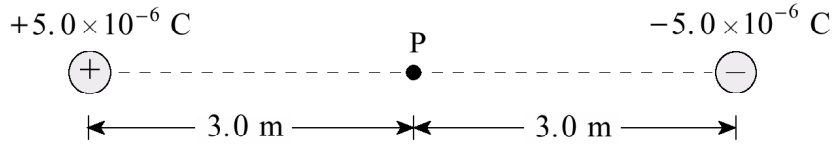

	MAGNITUDE OF ELECTRIC FIELD	ELECTRIC POTENTIAL
A.	0 N/C <input checked="" type="checkbox"/>	0 V <input checked="" type="checkbox"/>
B.	0 N/C <input checked="" type="checkbox"/>	30 000 V <input checked="" type="checkbox"/>
C.	10 000 N/C <input checked="" type="checkbox"/>	0 V <input checked="" type="checkbox"/>
D.	10 000 N/C <input checked="" type="checkbox"/>	30 000 V <input checked="" type="checkbox"/>

$$V = V_{\text{left}} + V_{\text{right}}$$

$$= \frac{kq_r}{r_r} + \frac{kq_l}{r_l} = \frac{(9 \times 10^9)(5 \times 10^{-6})}{3} + \frac{(9 \times 10^9)(-5 \times 10^{-6})}{3} = 0$$

24.

A charge q of $30.0 \mu\text{C}$ is moved from point X to point Y.

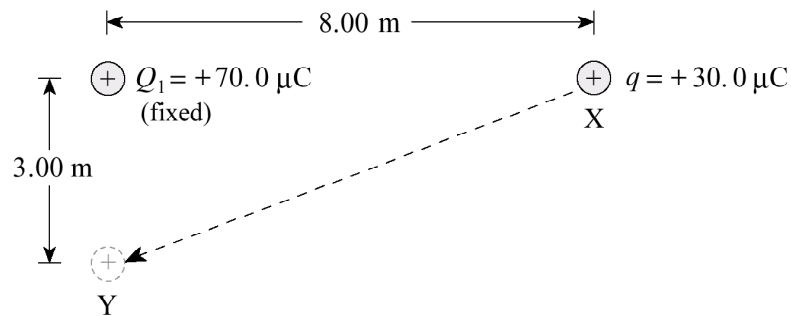

How much work is done on the $30.0 \mu\text{C}$ charge? ($1 \mu\text{C} = 1 \times 10^{-6} \text{ C}$)

(7 marks)

$$W = \Delta PE = PE_f - PE_i$$

$$= \frac{kq_1q_2}{r_f} - \frac{kq_1q_2}{r_i}$$

$$= \frac{(9 \times 10^9)(70 \times 10^{-6})(30 \times 10^{-6})}{3} - \frac{(9 \times 10^9)(70 \times 10^{-6})(30 \times 10^{-6})}{8}$$

$$= 6.3 - 2.36 = 3.94 \text{ J}$$

9908

25.

Which diagram shows the electric field near a negative point charge?

A.

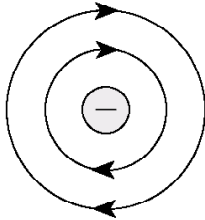

B.

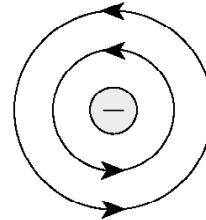

C.

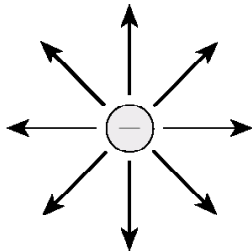

D.

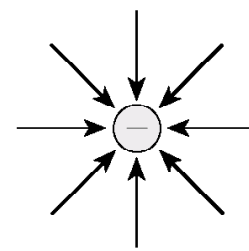

26.

Which pair of values will cause the greatest deflection of an electron beam in a cathode ray tube?

	ACCELERATING VOLTAGE	DEFLECTION (PLATE) VOLTAGE
A.	400 V ✓	20 V ✗
B.	400 V ✓	40 V ✓
C.	800 V ✗	20 V ✗
D.	800 V ✗	40 V ✓

small accelerating voltage

large deflection voltage

27.

The magnitude of the net electric field at P in the diagram below is 5.0×10^3 N/C.

$$\vec{E}_1 = \frac{kq_1}{r^2} = 4000 \text{ N/C}$$

Now draw vector diagram \rightarrow

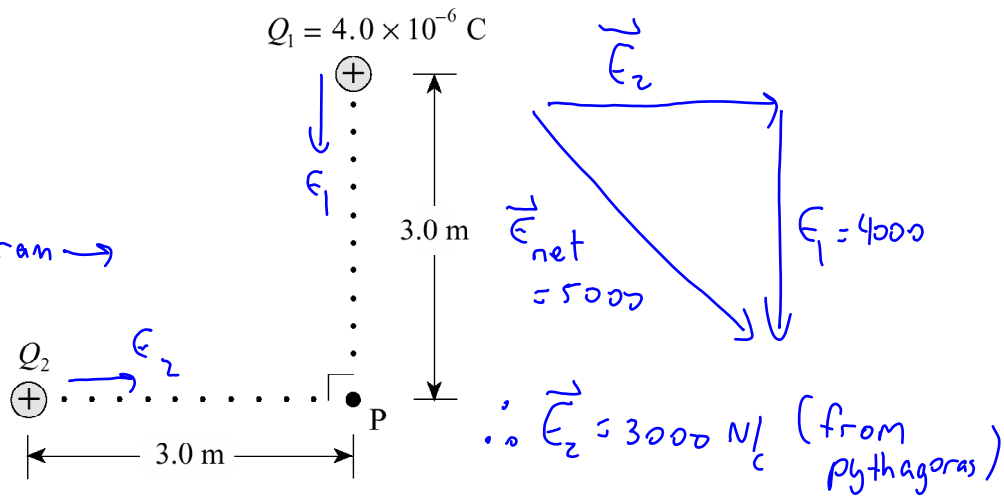

Find the magnitude of charge Q_2 .

- A. $1.0 \times 10^{-6} \text{ C}$
- B. $3.0 \times 10^{-6} \text{ C}$
- C. $6.4 \times 10^{-6} \text{ C}$
- D. $1.0 \times 10^{-5} \text{ C}$

$$\vec{E}_2 = \frac{kq_2}{r^2} \Rightarrow q_2 = \frac{r^2 E^2}{k} = \frac{(3^2)(3000^2)}{9 \times 10^9} = 3 \times 10^{-6} \text{ C}$$

28.

a) Find the electric potential at point A and at point B. (Note: $1.0 \mu\text{C}$ is $1.0 \times 10^{-6} \text{ C}$)

(3 marks)

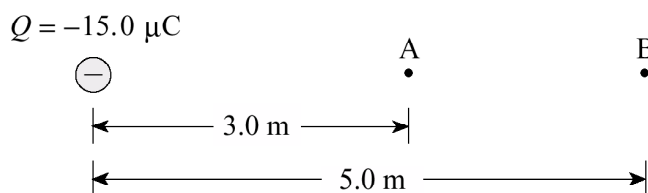

$$V_A = \frac{kq}{r_A} = \frac{(9 \times 10^9)(-15 \times 10^{-6})}{3} = -4.5 \times 10^4 \text{ V}$$

$$V_B = \frac{kq}{r_B} = \frac{(9 \times 10^9)(-15 \times 10^{-6})}{5} = -2.7 \times 10^4 \text{ V}$$

b) What is the potential difference between A and B?

(1 mark)

$$\Delta V = V_A - V_B = -45000 - -27000$$
$$= -18000 \text{ V}$$

ANSWER:

b) potential difference: $-1.8 \times 10^4 \text{ V}$

c) 0.036 J of work must be done to move a charge q from A to B. Find the magnitude and polarity of this charge. (3 marks)

$$Q = -15.0 \mu\text{C}$$

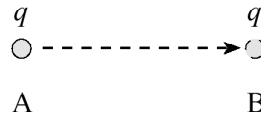

$$W = \Delta PE$$

$$.036 = q \Delta V$$

$$q = \frac{.036}{\Delta V} = \frac{.036}{18000} = 2.0 \times 10^{-6} \text{ C}$$

Since it takes positive work to move from A to B, the charge must be positive, since it doesn't want to move away from the $-15 \mu\text{C}$ charge.

$$\therefore q = +2.0 \times 10^{-6} \text{ C}$$

9906

29.

In a cathode ray tube,

- ~~A.~~ protons are accelerated from anode (positive) to cathode (negative).
- ~~B.~~ protons are accelerated from cathode (negative) to anode (positive).
- C. electrons are accelerated from anode (positive) to cathode (negative).
- D.** electrons are accelerated from cathode (negative) to anode (positive).

30.

Charge Q_1 is located 5.0 m from charge Q_2 as shown.

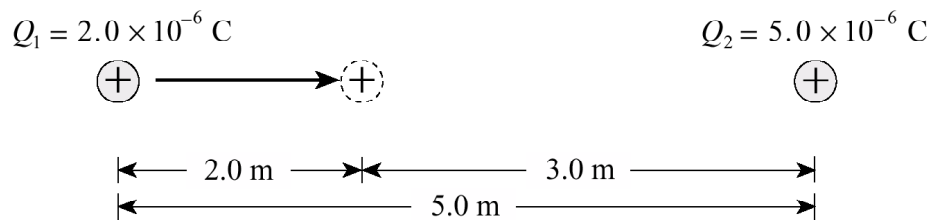

How much work must be done to move charge Q_1 2.0 m closer to charge Q_2 ?

- A. $7.2 \times 10^{-3} \text{ J}$
 - B. $1.1 \times 10^{-2} \text{ J}$
 - C.** $1.2 \times 10^{-2} \text{ J}$
 - D. $2.0 \times 10^{-2} \text{ J}$
- $W = \Delta PE = kq_1q_2 \left(\frac{1}{r_f} - \frac{1}{r_i} \right)$
 $= \frac{(9 \times 10^9)(2 \times 10^{-6})(5 \times 10^{-6})}{3} - \frac{(9 \times 10^9)(2 \times 10^{-6})(5 \times 10^{-6})}{5}$

31.

An electron orbits the nucleus of an atom with velocity v . If this electron were to orbit the same nucleus with twice the previous orbital radius, its orbital velocity would now be

- A. $\frac{v}{2}$
- B.** $\frac{v}{\sqrt{2}}$
- C. v
- D. $2v$

$F_e = F_c$

$\frac{kq_1q_2}{r^2} = \frac{mv^2}{r}$

replace r with $2r$

$$v = \sqrt{\frac{kq_1q_2}{rm}}$$

$$v_f = \sqrt{\frac{kq_1q_2}{2rm}}$$

32.

An electron passing between parallel plates 0.025 m apart experiences an upward electrostatic force of 5.1×10^{-16} N.

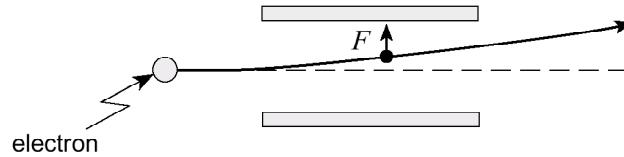

a) What is the magnitude of the electric field between the plates?

(3 marks)

$$\vec{E} = \frac{\vec{F}}{q} = \frac{5.1 \times 10^{-16}}{1.6 \times 10^{-19}} = 3188 \text{ N/C}$$
$$= 3.2 \times 10^3 \text{ N/C}$$

← voltage

b) What is the potential difference between the plates?

(2 marks)

$$\vec{E} = \frac{V}{d} \rightarrow V = Ed = (3188)(0.025) \\ = 79.6 \text{ V}$$

c) On the diagram below draw in the connections to the power supply necessary for the electron to experience this upward force. (2 marks)

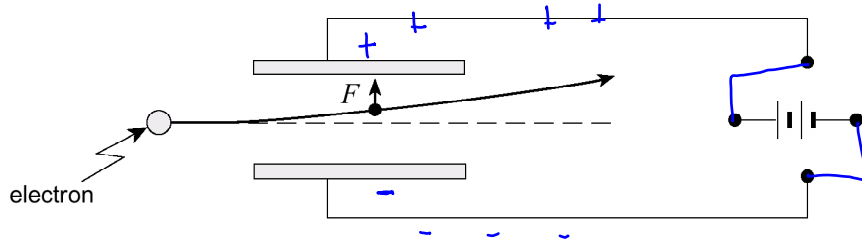

Note: in a battery:  ← positive
↑ negative

9901
33.

The diagram shows the electric field lines near two point charges, L and R. Identify the polarity of these point charges.

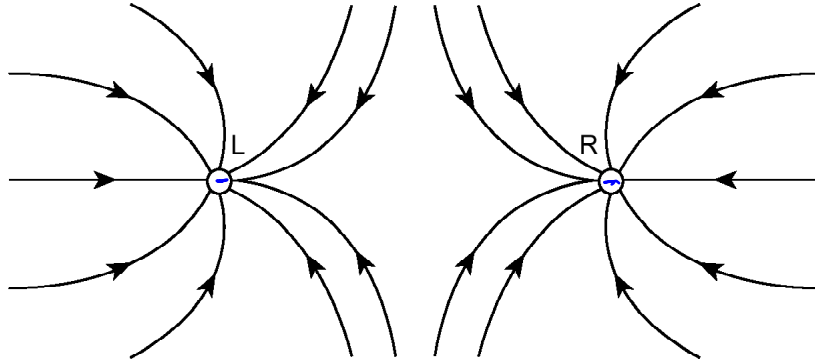

	POLARITY OF L	POLARITY OF R
A.	Negative ✓	Negative ✓
B.	Negative ✓	Positive ✗
C.	Positive ✗	Negative ✓
D.	Positive ✗	Positive ✗

34.

An electron orbits a nucleus which carries a charge of $+9.6 \times 10^{-19}$ C. If the electron's orbital radius is 2.0×10^{-10} m, what is its electric potential energy?

- A. -6.9×10^{-18} J
 B. -3.5×10^{-8} J
 C. 43 J
 D. 2.2×10^{11} J

$$PE = \frac{kq_1q_2}{r}$$

$$= \frac{(9 \times 10^9)(-1.6 \times 10^{-19})(9.6 \times 10^{-19})}{2 \times 10^{-10}}$$

$$= -6.9 \times 10^{-18} \text{ J}$$

35.

Two charges are positioned as shown in the diagram below.

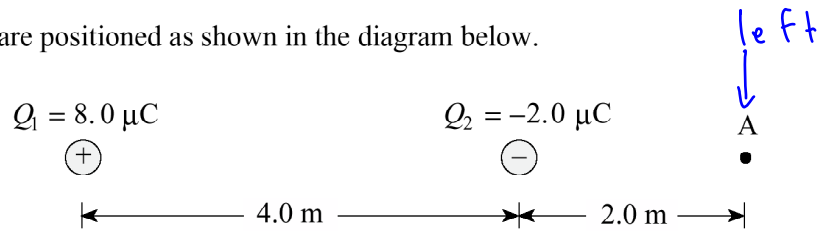

a) Find the magnitude and direction of the electric field at A. (Note: $1.0 \mu\text{C} = 1.0 \times 10^{-6} \text{ C}$)

(4 marks)

$$E_1 = \frac{kq_1}{r_1^2} = \frac{(9 \times 10^9)(8 \times 10^{-6})}{6^2} = 2000 \text{ N/C} \text{ right}$$

$$E_2 = \frac{(9 \times 10^9)(2 \times 10^{-6})}{2^2} = 4500 \text{ N/C} \text{ left}$$

$$E = 4500 - 2000 = 2.5 \times 10^3 \text{ N/C} \text{ left}$$

- b) A charge placed at A experiences a force of 4.0×10^{-3} N towards the right. What are the magnitude and polarity of this charge? (3 marks)

$$\vec{F} = \frac{F}{q}$$

$$q = \frac{F}{\vec{F}} = \frac{4 \times 10^{-3}}{2500} = -1.6 \times 10^{-6} \text{ C}$$

↑
negative

9808

36.

Which of the following correctly describes the polarity of the charges X and Y?

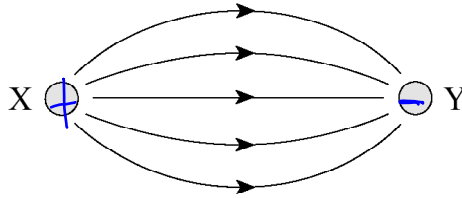

	POLARITY OF X	POLARITY OF Y
A.	Positive ✓	Negative ✓
B.	Positive ✓	Positive ✓
C.	Negative ✗	Negative ✓
D.	Negative ✗	Positive ✓

37.

Three positive charges are fixed as shown in the diagram below.



Calculate the net electric force on Q_2 due to Q_1 and Q_3 .

	MAGNITUDE OF FORCE	DIRECTION OF FORCE
A.	3.1 N	Left
B.	3.1 N	Right
C.	5.9 N	Left
D.	5.9 N	Right

$$F_{Q_1,2} = \frac{(9 \times 10^9)(4 \times 10^{-6})(5 \times 10^{-6})}{.2^2} = 4.5 \text{ N Right}$$

$$F_{Q_3,2} = \frac{k q_3 q_2}{r^2} = \frac{(9 \times 10^9)(5 \times 10^{-6})(8 \times 10^{-6})}{.5^2} = 1.44 \text{ N left}$$

$$\text{Net: } 4.5 - 1.44 = 3.1 \text{ N right}$$

38.

A cathode ray tube beam deflects to the location as shown in Diagram I when a certain voltage is applied to the deflecting plates.

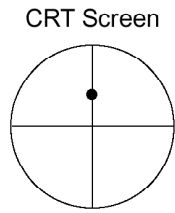

Diagram I

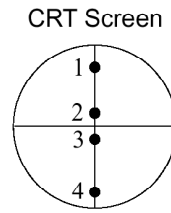

Diagram II

deflect
↓
down

The connections to the deflecting plates are then **reversed** and the deflecting voltage is **reduced**. Which location in Diagram II best represents the new beam position?

deflect
less

- A. Location 1
- B. Location 2
- C. Location 3
- D. Location 4

39.

An electron moving at 7.5×10^6 m/s enters an electric field between parallel plates by passing through a small hole in one of the plates.

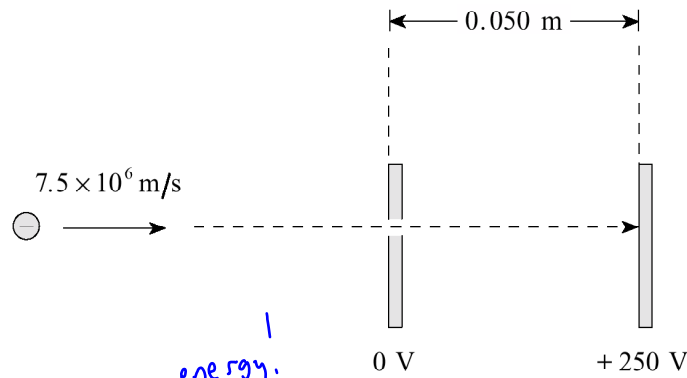

What is the impact speed of the electron on the second plate?

(7 marks)

$$PE_i + KE_i = \cancel{PE_f} + KE_f$$

↓ energy.

$$q\Delta V + \frac{1}{2}mv_i^2 = \frac{1}{2}mV_f^2$$

$$V_f^2 = \frac{(1.6 \times 10^{-19})(250) + \frac{1}{2}(9.11 \times 10^{-31})(7.5 \times 10^6)^2}{\frac{1}{2}(9.11 \times 10^{-31})} = 1.44 \times 10^{14}$$

$$V_f = \sqrt{1.44 \times 10^{14}} = 1.2 \times 10^7 \text{ m/s}$$

9806

40.

Which of the following best represents the electric field between oppositely charged parallel plates?

A.

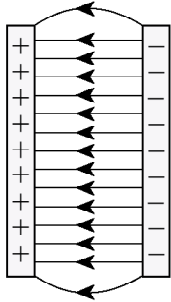

B.

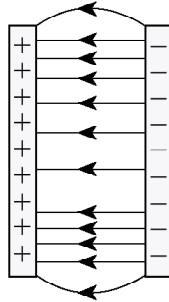

C.

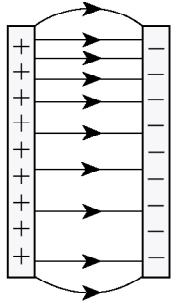

D.

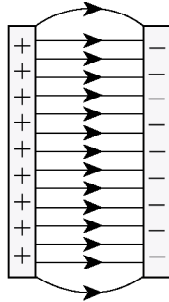

41.

Three point charges of equal magnitude but opposite sign are arranged as shown in the diagram below.

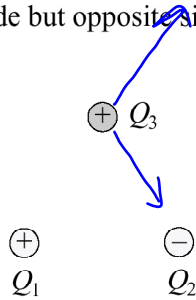

Which of the diagrams below best represents the electric forces acting on Q_3 due to the other two charges?

A.



B.

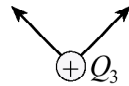

C.

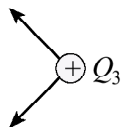

D.

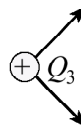

43.

Two point charges Q_1 and Q_2 are arranged as shown in the diagram below.

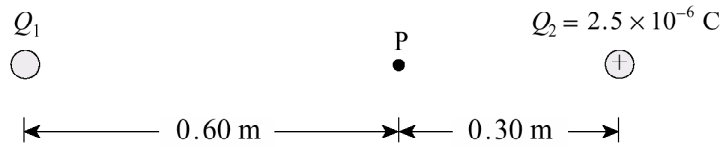

The electric potential at point P due to these charges is found to be $1.9 \times 10^5 \text{ V}$. What are the magnitude and sign of charge Q_1 ? **(7 marks)**

$$V = V_{Q_1} + V_{Q_2}$$

$$1.9 \times 10^5 = \frac{kq_1}{r_1} + \frac{kq_2}{r_2}$$

$$1.9 \times 10^5 - \frac{(9 \times 10^9)(2.5 \times 10^{-6})}{.3} = \frac{(9 \times 10^9)q_1}{.6}$$

$$115,000 = \frac{9 \times 10^9 q_1}{.6}$$

$$q_1 = \frac{(.6)(115,000)}{9 \times 10^9} = + 7.67 \times 10^{-6} \text{ C}$$

9801

44.

A cathode ray tube is adjusted so as to deflect the beam as shown.

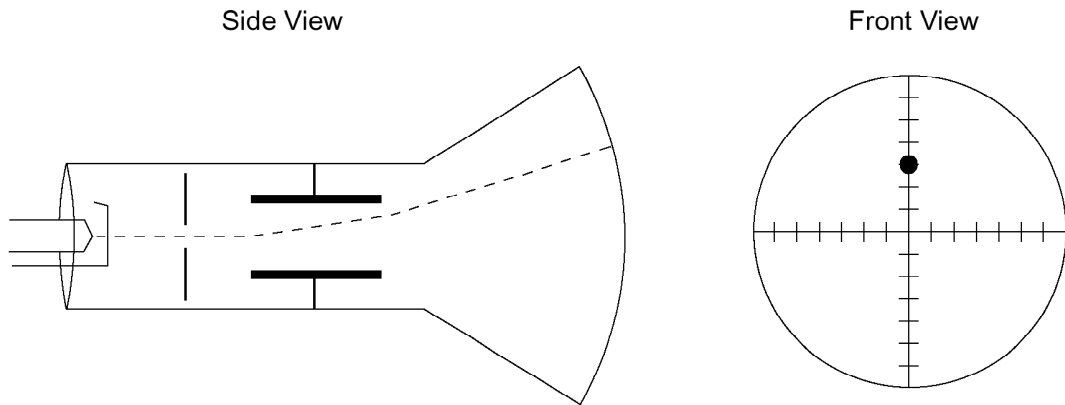

If the deflecting voltage is held constant and the accelerating voltage is then decreased, which diagram displays the new deflection?

bigger deflection

A.

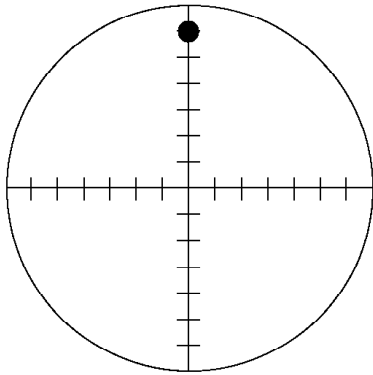

B.

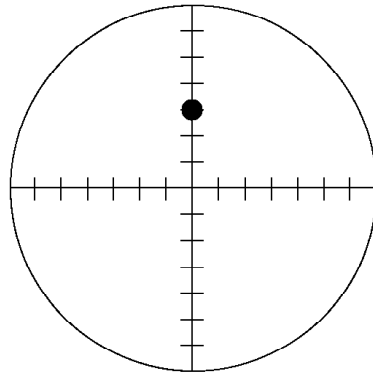

C.

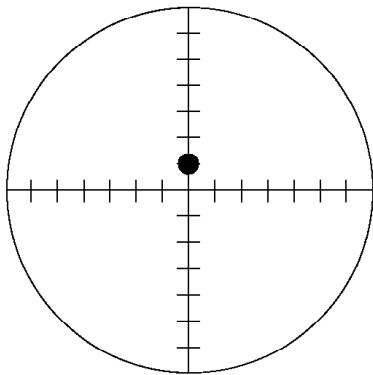

D.

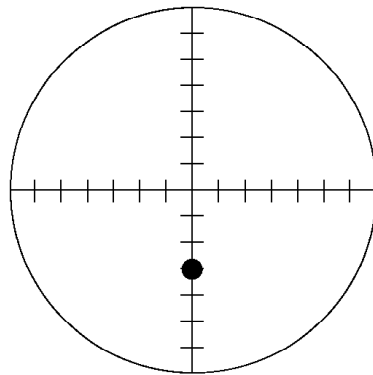

45.

What is the change in **kinetic energy** of an electron that moves from the negative plate to the positive plate in the situation shown below?

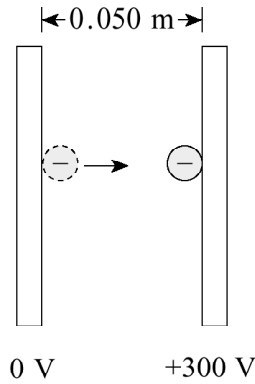

$$\Delta KE = -\Delta PE$$

$$\frac{1}{2}mv_f^2 - 0 = 0 - qV$$

$$= 0 - (-1.6 \times 10^{-19})(300)$$

$$= 4.8 \times 10^{-17}$$

- A. A gain of 4.8×10^{-17} J
- B. A loss of 4.8×10^{-17} J
- C. A gain of 9.6×10^{-16} J
- D. A loss of 9.6×10^{-16} J

46.

Two 2.0×10^{-6} C charges are positioned as shown in the diagram below.

Find work on left side,
then double it.

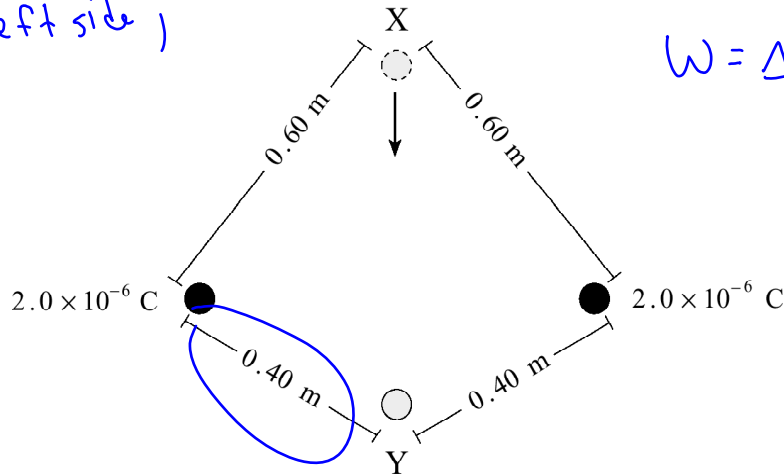

$$W = \Delta PE$$

What work must be done to move a 1.2×10^{-7} C charge from location X to location Y?

- A. 3.6×10^{-3} J
- B. 1.5×10^{-2} J
- C. 1.8×10^{-2} J
- D. 3.9×10^{-2} J

$$W = \frac{kq_1q_2}{r_f} - \frac{kq_1q_2}{r_i}$$

$$W = \frac{(9 \times 10^9)(1.2 \times 10^{-7})(2 \times 10^{-6})}{.4} - \frac{(9 \times 10^9)(1.2 \times 10^{-7})(2 \times 10^{-6})}{6}$$

$$W = .0054 - .0036 = .0018 \times 2 = 3.6 \times 10^{-3} \text{ J}$$

47.

Calculate the net electric field (magnitude and direction) at point P due to the two point charges shown in the diagram. **(7 marks)**

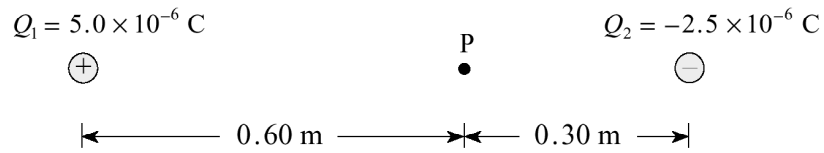

$$\vec{E}_1 = \frac{kq_1}{r^2} = \frac{(9 \times 10^9)(5 \times 10^{-6})}{.6^2} = 125,000 \text{ N/C Right}$$

$$\vec{E}_2 = \frac{(9 \times 10^9)(2.5 \times 10^{-6})}{.3^2} = 250,000 \text{ Right}$$

$$\text{total} : 3.75 \times 10^5 \text{ N/C Right}$$

Scholarship Questions (Nasty, but cool!)

9401

48. In one model of the hydrogen atom the electron orbits the proton at a distance of 5.3×10^{-11} m.

a) Calculate the electric potential energy of this electron. **(3 marks)**

b) Calculate the kinetic energy of this electron. **(5 marks)**

c) Calculate the total energy of this electron. **(2 marks)**

$$a) PE = \frac{kq_1q_2}{r} = \frac{(9 \times 10^9)(-1.6 \times 10^{-19})(+1.6 \times 10^{-19})}{5.3 \times 10^{-11}} = -4.35 \times 10^{-18} \text{ J}$$

b) need v! Think orbit!

$$F_c = F_e \rightarrow \frac{mv^2}{r} = \frac{kq_1q_2}{r^2} \rightarrow v^2 = \frac{kq_1q_2}{r m}$$

$$KE = \frac{1}{2}mv^2 = \frac{1}{2}m \left[\frac{kq_1q_2}{r m} \right] = \frac{1}{2} \left[\frac{(9 \times 10^9)(1.6 \times 10^{-19})(1.6 \times 10^{-19})}{5.3 \times 10^{-11}} \right]$$

$$KE = 2.17 \times 10^{-18} \text{ J}$$

$$c) \text{ Total Energy} = PE + KE = -2.17 \times 10^{-18} \text{ J}$$

9501

49.

Electric charges Q_1 and Q_2 are arranged as shown in the diagram below. Find the electric potential difference, V_{AB} , due to these charges. **(12 marks)**

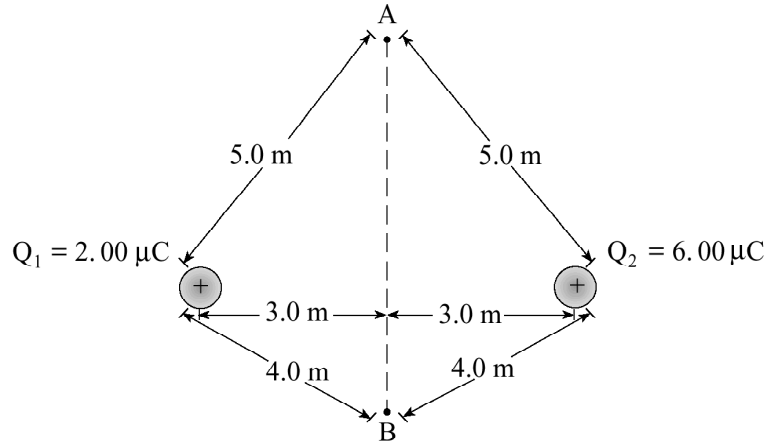

$$V_A = \frac{kq_1}{r_1} + \frac{kq_2}{r_2} = \frac{(9 \times 10^9)(2 \times 10^{-6})}{5} + \frac{(9 \times 10^9)(6 \times 10^{-6})}{5} = 14,400 \text{ v}$$

$$V_B = \frac{(9 \times 10^9)(2 \times 10^{-6})}{4} + \frac{(9 \times 10^9)(6 \times 10^{-6})}{4} = 18,000 \text{ v}$$

potential difference = ΔV

$$\Delta V_{AB} = 18,000 - 14,400 = 3.6 \times 10^3 \text{ v}$$

9506

50.

- a) A small sphere carrying 5 excess electrons is suspended between horizontal parallel plates as shown.

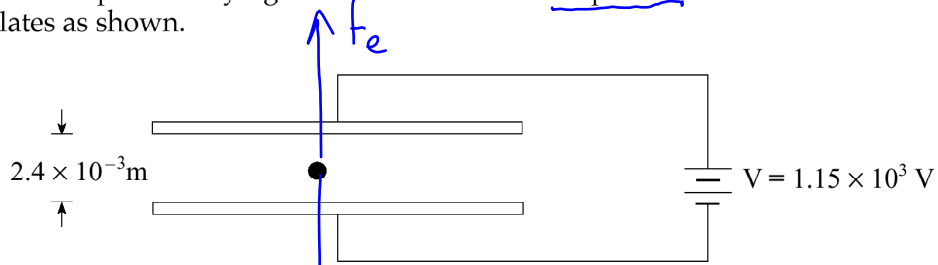

Find the mass of the sphere.

(6 marks)

$$F_e = F_g$$
$$q \vec{E} = mg$$
$$q \frac{\Delta V}{d} = mg$$
$$m = \frac{q \Delta V}{d g} = \frac{(5 \times 1.6 \times 10^{-19}) (1.15 \times 10^3)}{(2.4 \times 10^{-3}) (9.8)}$$
$$m = 3.9 \times 10^{-14} \text{ kg}$$

b) If the same apparatus is allowed to accelerate downwards in an elevator at 2.7 m/s^2 , what new plate voltage will maintain the sphere's position between the plates?

(6 marks)

$$F_g - F_e = ma \quad \leftarrow a = 2.7 \text{ m/s}^2$$



$$mg - q \frac{V}{d} = ma$$

$$mg - ma = q \frac{V}{d}$$

$$V = \frac{(mg - ma)d}{q} = \frac{m(g - a)d}{q}$$

$$V = \frac{(3.9 \times 10^{-14})(9.8 - 2.7)(2.4 \times 10^{-3})}{5 \times 1.6 \times 10^{-19}} = 830 \quad \text{V}$$

9601

51.

A small 4.0×10^{-3} kg charged sphere is suspended by a light thread between parallel plates, as shown in the diagram below. When the plates are connected to a 500 V source, the thread makes a 15° angle with the vertical.

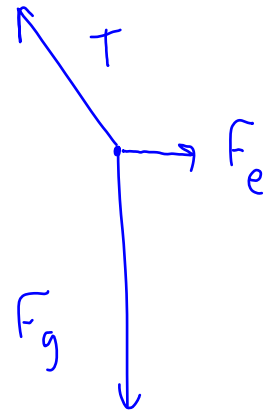
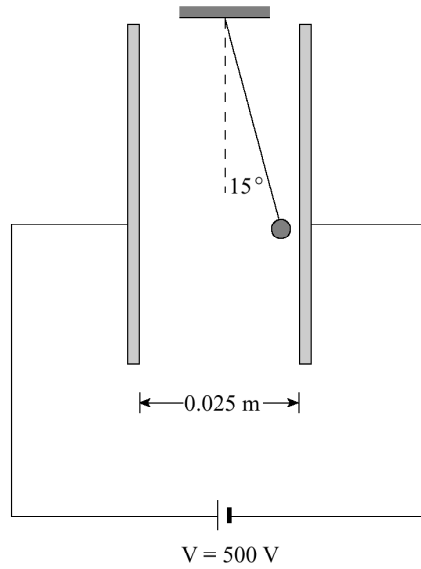

What is the charge on the sphere?

(12 marks)

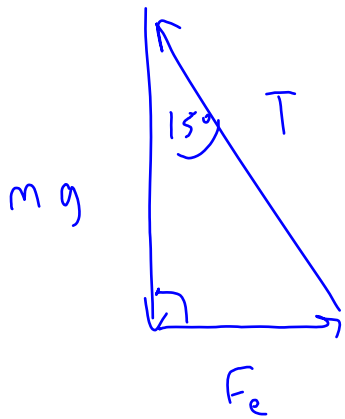

$$\tan 15^\circ = \frac{F_e}{mg}$$

$$F_e = mg \tan 15^\circ$$

$$q \vec{E} = mg \tan 15^\circ$$

$$q \frac{\Delta V}{d} = mg \tan 15^\circ$$

$$q = \frac{mgd \tan 15^\circ}{\Delta V} = \frac{(4 \times 10^{-3})(9.8)(.025) \tan 15^\circ}{500}$$

$$q = 5.3 \times 10^{-7} \text{ C.}$$

8906

52.

Two protons are separated by a distance of 1.5×10^{-9} m. If both protons are initially at rest and then one is released, what is the final speed of the released proton with respect to the fixed proton? **(10 marks)**

$$KE_i + PE_i = KE_f + PE_f$$

$$0 + \frac{kq_1q_2}{r_i} = \frac{1}{2}mv_f^2 + 0$$

$$v_f^2 = \frac{2kq_1q_2}{m r_i}$$

$$v_f^2 = \frac{2(9 \times 10^9)(1.6 \times 10^{-19})(1.6 \times 10^{-19})}{(1.67 \times 10^{-27})(1.5 \times 10^{-9})} = 1.83952 \times 10^8$$

$$v_f = 1.36 \times 10^4 \text{ m/s}$$

Answers:

1. d
2. d
3. b
4. a) $v=1.2 \times 10^7$ m/s
b) $F=7.2 \times 10^{-17}$ N
5. d
6. d
7. $V=4.3 \times 10^4$ v
8. see solution key
9. b
10. a
11. a
12. $E=2.3 \times 10^6$ N/c
13. d
14. b
15. b
16. $v=2.0 \times 10^6$ m/s
17. d
18. d
19. c
20. a) 2.4×10^{-15} J
b) $V=1.5 \times 10^4$ v
21. a
22. c
23. c
24. 3.9 J
25. d
26. b
27. b
28. a) $V_B=-27000$ v, $V_A=-45000$ v
b) $\Delta V = 18000$ v
c) $q=+2.0 \times 10^{-6}$ C
29. d
30. c
31. b
32. a) $E=3.2 \times 10^3$ N/c
b) $V=80$ v
c) see key
33. a
34. a
35. a) $E=2.5 \times 10^3$ N/c to left
36. a
37. b
38. c
39. $v=1.2 \times 10^7$ m/s
40. d
41. d
42. oops, I missed #42. Sorry!
43. $Q_1=+7.7 \times 10^{-6}$ C
44. a
45. a
46. a
47. $E=3.8 \times 10^5$ N/c to the right
48. a) -4.35×10^{-18} J
b) 2.7×10^{-18} J
c) -2.17×10^{-18} J
49. $V_{AB}=3.6 \times 10^3$ v
50. a) 3.9×10^{-14} kg
b) 833 v
51. $q=5.3 \times 10^{-7}$ C
52. $v= 1.4 \times 10^4$ m/s